



www.szcyt.com

3-Pin Microprocessor Reset Circuits

cyt809

Introductions

The cyt809 series are power supply supervisory circuits used to monitor the supply change in microprocessors and digital systems. The cyt809 series provide a reset to the microprocessors during system power-up, power-down and brown-out conditions.

The cyt809 is designed to monitor the V_{CC} supply voltage and assert a reset signal whenever the voltage declined below the preset threshold. The reset signal remains for at least 140ms after V_{CC} has risen above the threshold. The cyt809 provides an active-low reset output.

The cyt809 series are optimized to reject fast transient glitches on the V_{CC} line. Low power supply current of 10μA makes the cyt809 more suitable for battery-powered applications.

The cyt809 series are available in SOT23-3 package.

Features

- ◆ Precision monitoring of 2.63V/ 2.70V/ 2.93V/ 3.08V
- ◆ Fully specified over temperatures
- ◆ 140ms min. Power-On-Reset pulse width
- ◆ 10μA low supply current
- ◆ Power supply transient immunity

Applications

- ◆ Computers
- ◆ Controllers
- ◆ Portable / Battery-supplied devices
- ◆ Automotive

Ordering Information

Reset Threshold			Parts Number	SilkScreen
Min	Typ.	Max		
2.59	2.63	2.66	cyt809R	AFAA
2.59	2.63	2.66	cyt809RA	ARxxx
2.66	2.7	2.73	cyt809V	
2.89	2.93	2.96	cyt809S	ADAA
2.89	2.93	2.96	cyt809SA	ASxxx
3.04	3.08	3.11	cyt809T	ACAA
3.04	3.08	3.11	cyt809TA	

Pinout Diagram

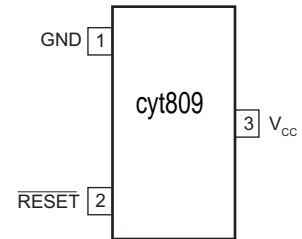

Typical Application

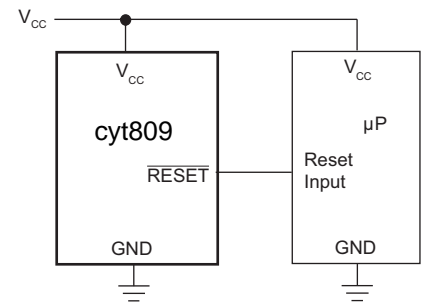

Absolute Maximum Ratings

V_{CC}	- 0.3V to +6.0V	Continuous Power Dissipation (derate 2.17mW/°C above +70°C)	320mW
\overline{RESET}	- 0.3V to ($V_{CC} + 0.3V$)	Ambient Temperature Range	- 40°C to +105°C
Input Current, V_{CC}	20mA	Maximum Junction Temperature	125°C
Output Current, \overline{RESET}	20mA	Storage Temperature Range	- 65°C to +160°C
Rate of Rise, V_{CC}	100V/ μ s	Lead Temperature (soldering, 10s)	+300°C

Electrical Characteristics

V_{CC} = full range, T_A = -40°C to +105°C, unless otherwise noted. Typical values are at T_A = +25°C, V_{CC} = 3.3V for 2.93/3.08V versions, and V_{CC} = 3V for 2.7V/2.63V version.

Symbol	Parameter	Conditions	Min	Typ	Max	Units
	V_{CC} Range	$T_A = 0^\circ\text{C to } +70^\circ\text{C}$	1.0		5.5	V
		$T_A = -40^\circ\text{C to } +105^\circ\text{C}$	1.2		5.5	
I_{CC}	Supply Current	$V_{CC} < 3.6V$		10	20	μ A
V_{TH}	Reset Threshold	cyt809R $T_A = +25^\circ\text{C}$	2.59	2.63	2.66	V
		cyt809RA $T_A = +25^\circ\text{C}$	2.59	2.63	2.66	
		cyt809V $T_A = +25^\circ\text{C}$	2.66	2.7	2.73	
		cyt809S $T_A = +25^\circ\text{C}$	2.89	2.93	2.96	
		cyt809SA $T_A = +25^\circ\text{C}$	2.89	2.93	2.96	
		cyt809T $T_A = +25^\circ\text{C}$	3.04	3.08	3.11	
		cyt809TA $T_A = +25^\circ\text{C}$	3.04	3.08	3.11	
	Reset Active Timeout	$T_A = -40^\circ\text{C to } +85^\circ\text{C}$	140	240	560	ms
V_{OL}	\overline{RESET} Output Voltage Low	$V_{CC} = V_{TH} \text{ min, } I_{SINK} = 1.2\text{mA}$			0.3	V
		$V_{CC} > 1.4V, I_{SINK} = 50\mu\text{A}$			0.3	
V_{OH}	\overline{RESET} Output Voltage High	$V_{CC} > V_{TH} \text{ max, } I_{SOURCE} = 500\mu\text{A}$	$0.8V_{CC}$			V

Typical Performance Characteristics

Supply Current vs. Temperature
(No Load, 2.63/2.7/2.93/3.08)

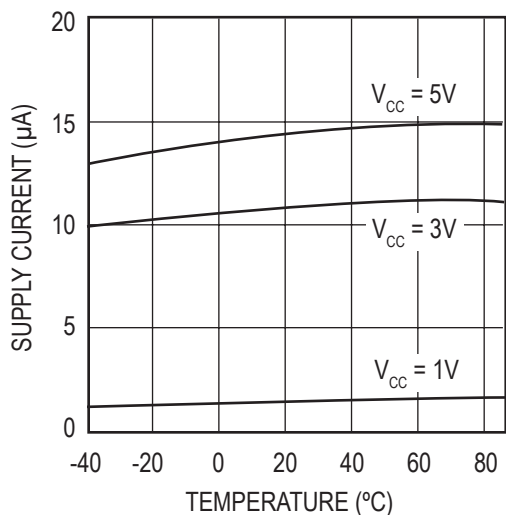

Power Up Reset Timeout vs. Temperature

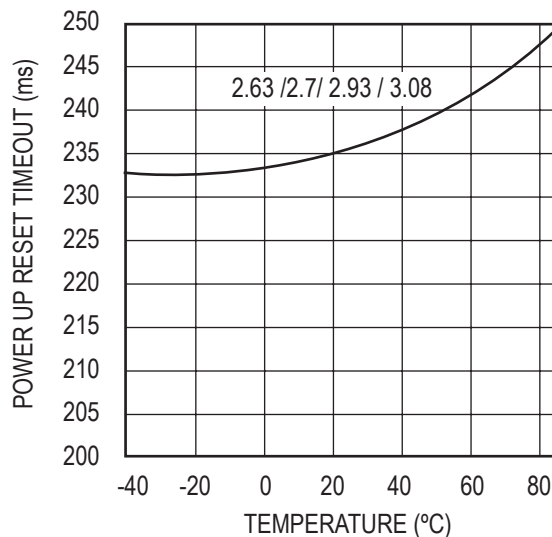

Power-Down Reset Delay vs. Temperature
(2.63/2.7/2.93/3.08)

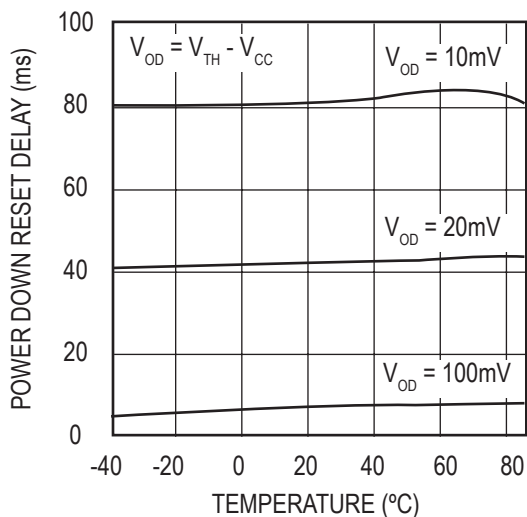

Normalized Reset Threshold vs. Temperature

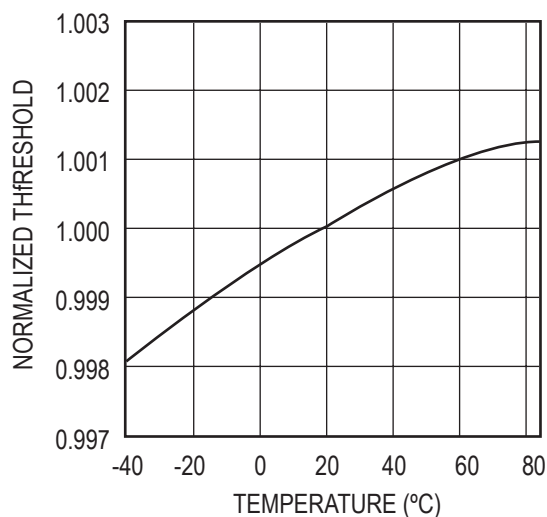

Application Information

Detailed Operation Description

The cyt809 series microprocessor reset circuits are designed to monitor the power supplies in digital systems and provide a reset signal to the processor under the preset conditions. Initially consider that the input voltage is within the upper and lower threshold, the reset output pin of the cyt809 is high. When voltages falls under the preset lower threshold, the **RESET** output pin will be driven low to assert reset to the microprocessor. After the power interruption, V_{CC} will rise to its nominal level above the threshold voltage while the reset signal will keep asserting for a preset period. During the reset process, the cyt809 internal oscillator circuitry is activated to count the signal asserting period. When the preset asserting period times out, the reset signal will revert back to high.

Figure 1. cyt809 Reset Timing Diagram

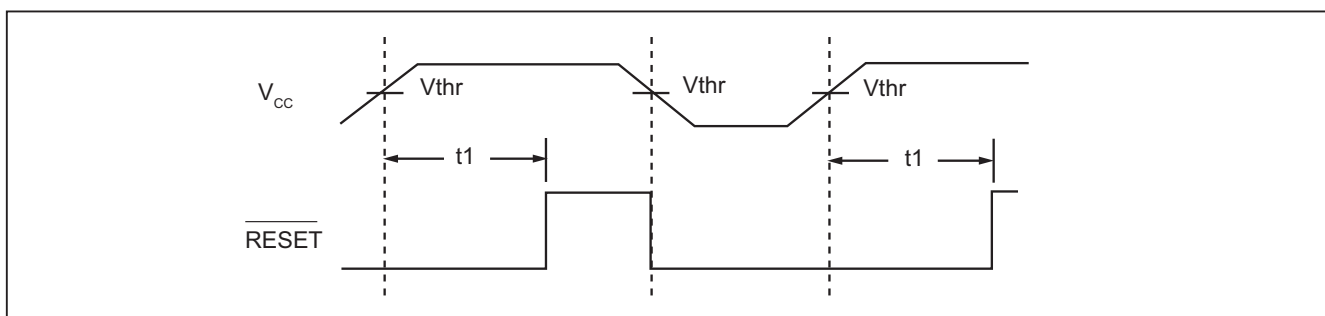

V_{CC} Transient Rejection

The cyt809 series provides accurate power supply monitoring and resets during power-up, power-down and brown-out conditions. It also provides negative-going transients and glitch at the power supply to avoid unwanted resets. The transient rejection feature is achieved by the preset maximum tolerable transient duration and the overdrive scale. Either condition failing to exceed the limits will not generate a reset. Typically, transients that go 100mV below the reset threshold and last 5.0 μ s or less will not trigger a reset. Transient immunity can be further improved by adding a capacitor in close proximity to the V_{CC} pin of the cyt809.

Enable Reset during Power-down

When V_{CC} falls below 1V, the cyt809 **RESET** output no longer sinks current. This will cause the CMOS logic inputs to the microprocessor floating at an underdetermined voltage. Most digital systems are shutdown well above this voltage. However, in situations where **RESET** must be maintained valid to $V_{CC} = 0V$, a pull-down resistor must be connected from **RESET** to ground to discharge stray capacitance and hold the output low. A 100k Ω resistor will be suitable for most applications.

Processors with Bi-directional I/O Pins

When the cyt809 is to use with microprocessors with a bi-directional reset pin, logic conflict may take place and cause undermined logic level. To avoid such situation, a 4.7K Ω resistor shall be connected in series between the cyt809 **RESET** pin and the microprocessor reset interface. If there are other components requiring a reset signal, a buffer shall be added between the reset pin and the other system components.

Packaging Details

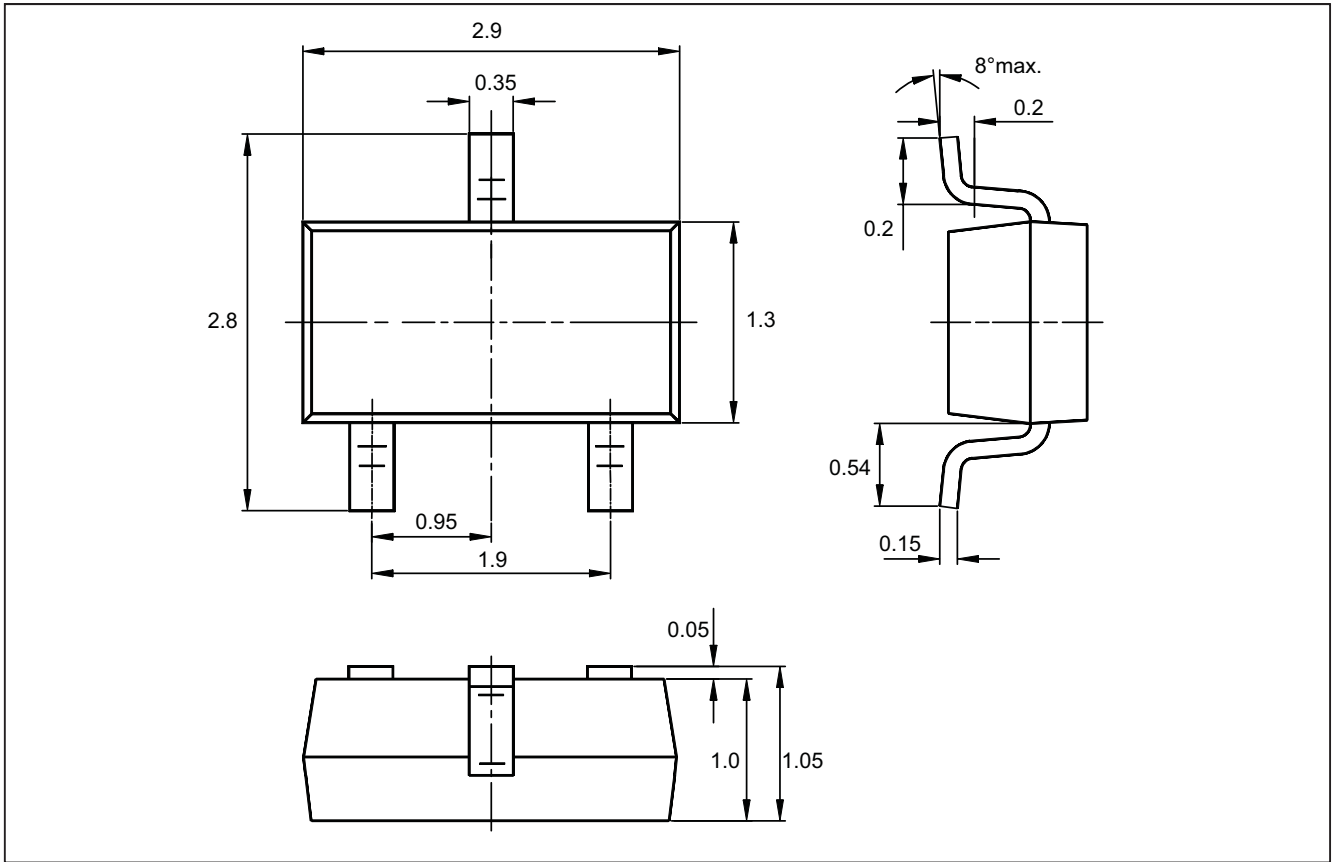



SHENZHEN CYT OPTO-ELECTRONIC TECHNOLOGY CO.,LTD.

IMPORTANT NOTICE

SHENZHEN CYT OPTO-ELECTRONIC TECHNOLOGY CO.,LTD. reserves the right to make changes without further notice to any products or specifications herein. SHENZHEN CYT OPTO-ELECTRONIC TECHNOLOGY CO.,LTD. does not assume any responsibility for use of any its products for any particular purpose, nor does SHENZHEN CYT OPTO-ELECTRONIC TECHNOLOGY CO.,LTD. assume any liability arising out of the application or use of any its products or circuits. SHENZHEN CYT OPTO-ELECTRONIC TECHNOLOGY CO.,LTD. does not convey any license under its patent rights or other rights nor the rights of others.

MAIN SITE(China):

SHENZHEN CYT OPTO-ELECTRONIC TECHNOLOGY CO.,LTD.

Address: Rm201-205, Building 4, Software park, Gaoxin center 2nd Rd, Nanshan District, Shenzhen

TEL:+86-755-86168222 FAX:+86-755-86168622 Technical support:+86-755-86169530

Business mail address: cyt@szcyt.com Website: www.szcyt.com